

Multistage Self Priming Boiler Feed Pumps

With Italian technology

applications

Handling fluids free from abrasive suspended solids

Aggressive liquids

For boiler feeding and condensate recovery

Circulation of lubrication oils

For handling liquids with vapour

Barrel unloading

Booster application

a
multistage
pump
for handling
liquids with
vapour

VA

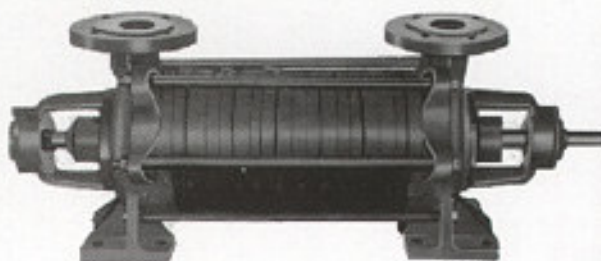

range

Capacity : upto 12m^3 /hr.

Total Head : upto 200 mtrs.

Max. Press. : upto 26 bars

Max. Temp. : upto 105°C

Available in graded Cast Iron, CI/Bronze, CI/CF-8M and CF-8M

special features

Pumps are multistage and self priming. Maximum suction is 5 MWC.

Pumps can be supplied with mechanical seals on both sides.

*Satisfying
diverse & exacting needs
of the customers
since 1984*

Part list overleaf

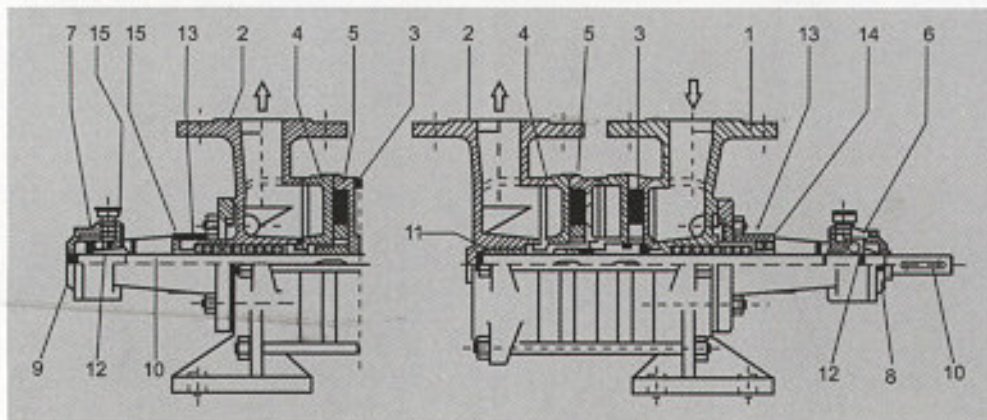

design

Owing to their particular construction, after initial filling, the pumps start operating even when the suction pipes are empty. Thus they can handle liquids as well as gases.

They have, either a normal frame bracket (ball bearing and bushing) or a double frame bracket (ball bearing and ball bearings).

The pumps are used for handling fluids which do not contain abrasive suspended solids.

Manufacturing since 1984

AURO PUMPS PVT. LTD.



In technical collaboration with Pompe Vergani S.p.A. of Italy

VA

Multistage Self Priming Boiler Feed Pump

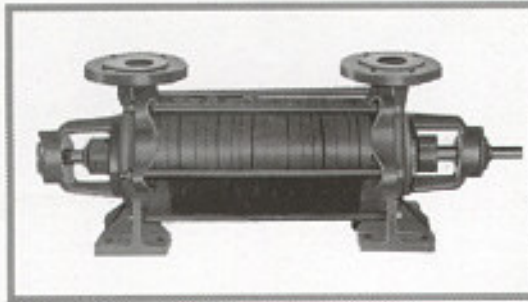

MODEL	SUC. & DIS. SIZE	RPM	Q=LPM		H=MTR				CV=BHP		
			Q	H	5	10	20	30	40	CV	BHP
VA 251	25	1450	Q	5	10	20	30	40			
			H	20.25	19.8	15.3	9.9	4.5			
			CV	0.5	0.45	0.4	0.32	0.3			
VA 252	25	1450	H	40.5	39.6	30.6	19.8	9			
			CV	0.9	0.85	0.75	0.6	0.55			
			H	60.75	59.4	45.9	29.7	13.5			
VA 253	25	1450	CV	1.3	1.25	1.1	0.85	0.75			
			H	81	79.2	61.2	39.6	18			
			CV	1.7	1.65	1.45	1.1	1			
VA 254cc	25	1450	Q	10	20	30	40	50	60		
			H	28.8	23.4	18	12.6	7.2	1.8		
			CV	0.9	0.8	0.6	0.55	0.4	0.2		
VA 201	32	1450	H	57.6	46.8	36	25.2	14.4	3.6		
			CV	1.7	1.5	1.3	1.1	0.8	0.4		
			H	86.4	70.2	54	37.8	21.6	5.4		
VA 302	32	1450	CV	2.4	2.2	1.8	1.6	1.2	0.6		
			H	115.2	93.6	72	50.4	28.8	7.5		
			CV	3.2	2.9	2.4	2.1	1.6	0.8		
VA 303	32	1450	H	144	117	90	63	36	9		
			CV	4	3.6	3.1	2.6	2	1		
			H	173	140.4	108	75.6	43.2	10.8		
VA 304cc	32	1450	CV	4.8	4.3	3.7	3.1	2.4	1.2		
			Q	20	30	40	50	60	80		
			H	36	32.4	29.25	26.1	22.5	13.5		
VA 311	32	1450	CV	1.5	1.4	1.3	1.2	1.1	1		
			H	72	64.8	58.5	52.2	45	27		
			CV	2.8	2.7	2.5	2.3	2.2	2		
VA 312	32	1450	H	108	97.2	87.3	78.3	67.5	40.5		
			CV	4.1	4	3.7	3.4	3.3	3		
			H	144	129.6	116.1	104.4	90	54		
VA 313	32	1450	CV	5.4	5.3	4.9	4.5	4.4	4		
			H	180	162	135.9	130.5	112.5	67.5		
			CV	6.7	6.6	6.1	5.6	5.5	5		
VA 314cc	32	1450	Q	50	60	80	100	125	150		
			H	24.3	22.5	19.35	16.2	12.6	9		
			CV	1.7	1.5	1.45	1.4	1.3	1.2		
VA 315cc	32	1450	H	48.6	45	38.7	32.4	25.2	18		
			CV	3.2	2.9	2.7	2.5	2.4	2.2		
			H	72.9	67.5	58.05	48.6	37.8	27		
VA 351	32	1450	CV	4.7	4	3.9	3.6	3.5	3.2		
			H	97.2	90	77.4	64.8	50.4	36		
			CV	6.2	5.2	5.1	4.7	4.6	4.2		
VA 352	32	1450	H	121.5	112.5	96.3	81	63	45		
			CV	7.7	6.4	6.3	5.8	5.7	5.2		
			Q	80	100	125	150	175	200		
VA 353	32	1450	H	30.6	27	22.5	18	13.5	9		
			CV	2.5	2.4	2.2	1.8	1.5	1.2		
			H	61.2	54	45	36	27	18		
VA 354cc	32	1450	CV	4.8	4.7	4.3	3.5	3	2.4		
			H	91.8	81	67.5	54	40.5	27		
			CV	7.1	7	6.4	5.2	4.5	3.6		
VA 355cc	32	1450	H	122.4	108	90	72	54	36		
			CV	9.4	9.3	8.5	6.9	6	4.8		
			H	153	135	112.5	90	67.5	45		
VA 401	32	1450	CV	11.75	11.62	10.62	8.62	7.5	6		
			H	183.6	162	135	108	81	54		
			CV	14.1	13.95	12.75	10.35	9	7.2		
VA 402	32	1450	H	61.2	54	45	36	27	18		
			CV	4.8	4.7	4.3	3.5	3	2.4		
			H	91.8	81	67.5	54	40.5	27		
VA 403	32	1450	CV	7.1	7	6.4	5.2	4.5	3.6		
			H	122.4	108	90	72	54	36		
			CV	9.4	9.3	8.5	6.9	6	4.8		
VA 404cc	32	1450	H	153	135	112.5	90	67.5	45		
			CV	11.75	11.62	10.62	8.62	7.5	6		
			H	183.6	162	135	108	81	54		
VA 405cc	32	1450	CV	14.1	13.95	12.75	10.35	9	7.2		
			H	61.2	54	45	36	27	18		
			CV	4.8	4.7	4.3	3.5	3	2.4		
VA 406cc	32	1450	H	91.8	81	67.5	54	40.5	27		
			CV	7.1	7	6.4	5.2	4.5	3.6		
			H	122.4	108	90	72	54	36		

AURO PUMPS A choice you will never regret

PART LIST (Drawing overleaf)

1. Suction Casing
2. Discharge Casing
3. Suction Disc
4. Discharge Disc
5. Impeller
6. Bearing Housing
7. Line Bearing Housing
8. Bearing Cover
9. Line Bearing Housing Cover
10. Shaft
11. Sleeve
12. Ball Bearing
13. Gland
14. Threaded Locking Ring (Suction Side)
15. Threaded Locking Ring (Discharge Side)

the **AURO**
range

ACC CHEMICAL PROCESS PUMPS

ACC THERMIC FLUID PUMPS

ACCV VERTICAL SUBMERGED PUMPS

PN MULTI STAGE BOILER FEED PUMPS

ASP NON-CLOG SELF PRIMING PUMPS

SUBMERSIBLE PUMPSET FOR 4", 6" & 8" BORE

MONOBLOCK PUMPSET UPTO 10 H.P.

SUBMERSIBLE HORIZONTAL MONOBLOCK PUMPSET FOR OPEN WELL UPTO 7.5 H.P.

ELECTRIC MOTORS

New Era Engineers and Traders

No. 11 D, Errabalu Chetty St, Parrys, Chennai - 600001.

Phone : +91-44-25341238 or 42053759, Fax : +91-44-25340578.

Email : neecomotor@airtelbroadband.in



NEW ERA

Pumping & Primover Solution Co. ...